



## DEMO BOARD TEST REPORT

### 108~150VAC/60HZ, PF>0.7, CW 140V/55mA and RGB 140V/12mA Five-Channel Linear Solution for Smart LED with KP18058

#### FEATURES

- PF > 0.7
- PST<1, SVM<1
- Fast Startup Time <0.3S Even at Minimum Dimming
- 0.1% Dimming Depth
- No Audible Noise
- Constant Input Power with Line Compensation Function
- PWM Dimming for RGB Channels
- Analog Dimming for CW Channels
- Thermal Protection
- Single layer PCB at a low cost

#### GENERAL DESCRIPTION

The Demo Board is designed to demonstrate the high performance of KP18058. KP18058 is a high-precision five-channel LED linear constant current dimming controller. It can independently set the output current of five channels by I<sup>2</sup>C (Inter-Integrated-Circuit Bus) to support various scenes. KP18058 integrates line compensation function, which can easily meet the requirements of constant input power without additional components. And it integrates OTP functions which will automatically reduce the output current to ensure the safety and reliability of the system. And it meets the EN55015B conducted and radiated EMI requirement.

The Demo Board is typically designed for 9W application with 108-150Vac input, 140V/55mA output of the CW channels and 140V/12mA output of the RGB channels within A60 LED Bulb.

#### APPLICATIONS

- LED Smart Lighting with Wireless Control

#### DEMO BOARD SEPCIFICATION

Description	Symbol	Min	Type	Max	Unit	Note	
Input Voltage	Vin	108		150	Vac	60Hz	
Output	Vout/Iout	CW: 140V/55mA; RGB:140V/12mA					
System Efficiency	$\eta$	80			%	120Vac/60Hz	
Power Factor	PF	0.7				120Vac/60Hz	
Startup Time	Tst			300	ms	120Vac/60Hz	
Standby Power				200	mW	120Vac/60Hz	
Conducted EMI Margin		6			dB		
Radiated EMI Margin		6			dB		
Surge Test		1			kV		

**Note:** The table above shows the minimum acceptable performance of the design. Actual performance is listed in the results section.

Demo Board of KP18058+KP35026\_D02\_REV1.0

Part A

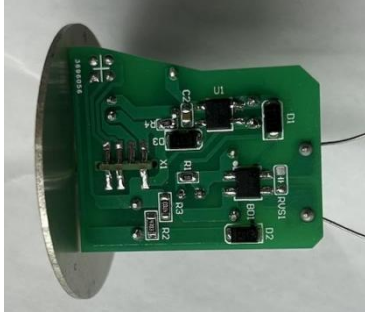

Part B

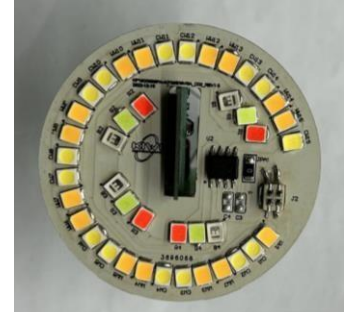
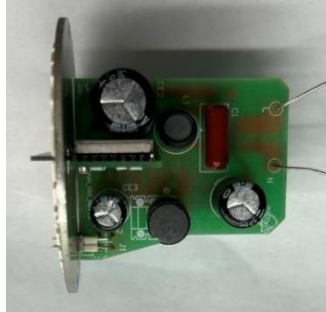

Printed Circuit Board Layout

Part A (MAIN) Top Layer

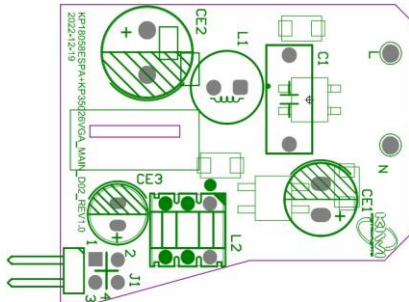

Part A (MAIN) Bottom Layer

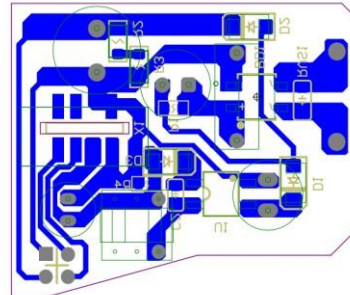

Part A (WIFI) Top Layer

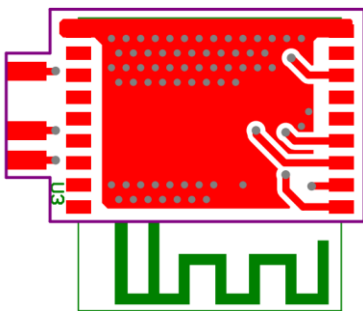

Part A (WIFI) Bottom Layer

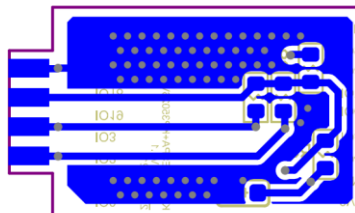

Part B (LED) Top Layer

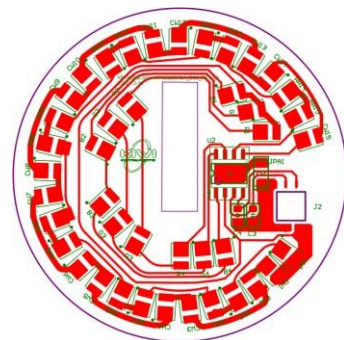

Schematic

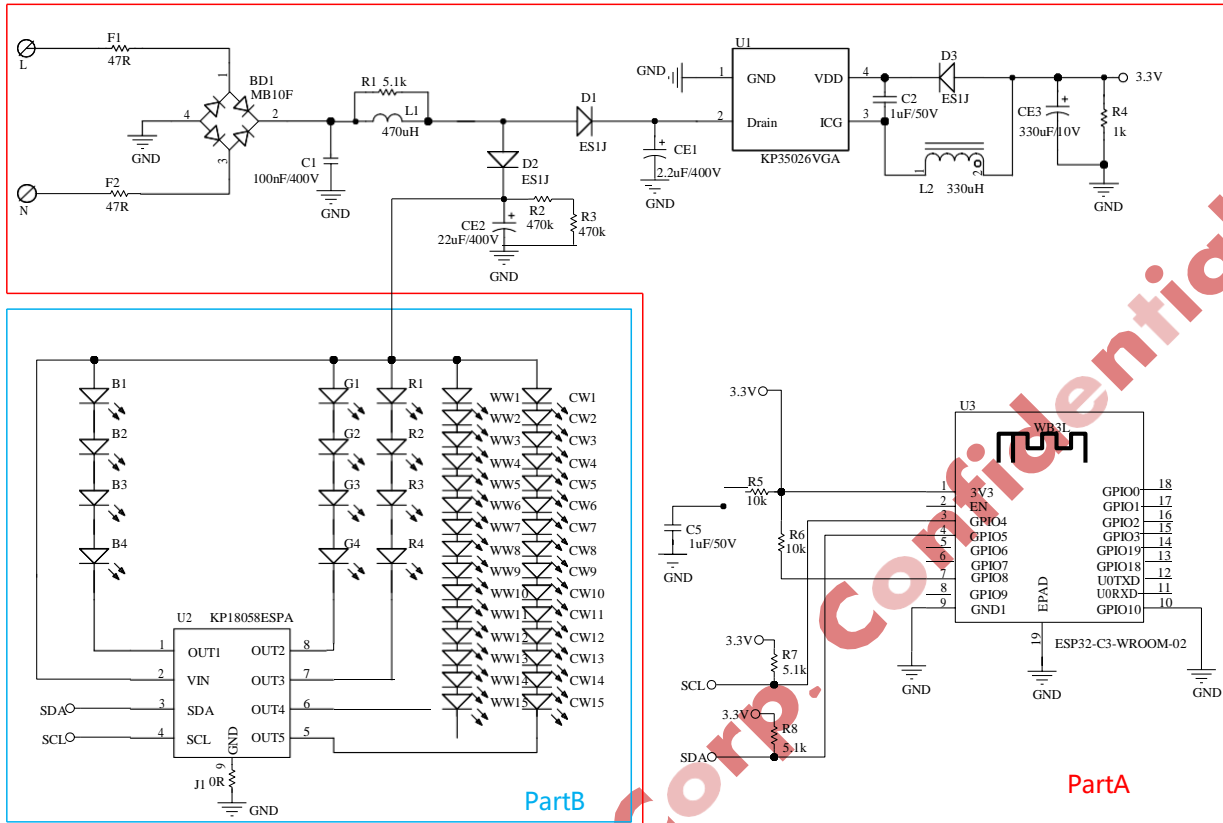

Kiwi Instruments Corp. Confidential



**108~150VAC/60HZ, PF>0.7, CW 140V/55mA and RGB 140V/12mA  
Five-Channel Linear Solution for Smart LED with KP18058**

**Bill of Material**

**Part A (MAIN)**

No.	Designator	Value	Description	Package	Manufacturer	Part Number
1	BD1	1000V/1A	BRD 1A 1000V 1.1V	MBF	World	MB10F
2	C1	100nF/400V	CBB 400Vdc 12*5*9 P10	TH	STE	B22G104JN1B01 20090050EOZ
3	C2	1µF/50V	Ceramic Cap 50V ±10% X7R	0805	WE	885012207103
4	CE1	2.2µF/400V	Electrolytic Cap 400V 8*12 P3.5	TH	AISHI	EW2H2GM2R2F1 2OT
5	CE2	22µF/400V	Electrolytic Cap 400V 10*16 P5.0	TH	AISHI	EGM2GM150G1 6OT3
6	CE3	330µF/10V	Electrolytic Cap 10V 6.3*11 P2.5	TH	AISHI	EW1H1AM331E11 OT
7	D1, D2, D3	600V/1A	DIO FRD 1A 600V 35nS 1.7V	SMA	MDD	ES1J
8	F1, F2	47R	Fuse Resistor ±5% 1W	TH	SY	RFB01J47R0A52 0SC
9	L1	470µH	Inductor Isat 0.31A Rdc 1.68Ω 6*8	TH	FH	VLU0608-471KB
10	L2	330µH	Inductor Isat 0.88A Rdc 0.70Ω 8*9.5	TH	WE	7447720331
11	R1	5.1k	Chip Resistor ±1% 1/8W	0805	FH	RS-05K5101FT
12	R2, R3	470k	Chip Resistor ±1% 1/4W	1206	FH	RS-06K4703FT
13	R4	1k	Chip Resistor ±1% 1/8W	0805	FH	RS-05K3900FT
14	U1	-	Low Cost Fast Dynamic Response Non-isolated PWM Power Switch	SOP-4	KIWI	KP35026VGA

**Part A (WIFI)**

No.	Designator	Value	Description	Package	Manufacturer	Part Number
15	C5	1µF/50V	Ceramic Cap 50V ±10% X7R	0805	WE	885012207103
16	R5, R6	10k	Chip Resistor ±1% 1/8W	0805	FH	RS-05K1002FT
17	R7, R8	5.1k	Chip Resistor ±1% 1/8W	0805	FH	RS-05K5101FT
18	U3	-	ESP32-C3-WROOM-02	WB3L	ESPRESSIF	/

**Part B (LED)**

No.	Designator	Value	Description	Package	Manufacturer	Part Number
19	J1	0R	Chip Resistor ±1% 1/4W	1206	FH	RS-06000FT
20	U2	-	Five-Channel High-Voltage Linear LED Dimming Driver	ESOP-8	KIWI	KP18058ESPA
21	B1~B4	Blue LED	LED Voltage 36V	2835	Any	B1~B4
22	G1~G4	Green LED	LED Voltage 36V	2835	Any	G1~G4
23	R1~R4	Red LED	LED Voltage 36V	2835	Any	R1~R4
24	WW1~WW14	Warm LED	LED Voltage 9V	2835	Any	WW1~WW14
25	WW15	Warm LED	LED Voltage 18V	2835	Any	WW15
26	CW1~CW14	Cool LED	LED Voltage 9V	2835	Any	CW1~CW14
27	CW15	Cool LED	LED Voltage 18V	2835	Any	CW15



**108~150VAC/60HZ, PF>0.7, CW 140V/55mA and RGB 140V/12mA  
Five-Channel Linear Solution for Smart LED with KP18058**

## Test Result

### 1. Steady characteristics

#### 1.1 System Efficiency

**Standard:** PF>0.7,  $\eta$ >80% @ 120Vac input & full load

**Result:** Pass

Vin(Vac)	Fline(Hz)	Pin(W)	Vo(V)	Io(mA)	PF	Eff(%)
108	60	4.75	130.3	31.13	0.692	85.39
120		9.02	134.8	54.4	0.736	81.30
132		11.56	136.2	63.6	0.739	74.93
140		11.5	135.2	59.3	0.725	69.72
150		10.8	133.8	51.6	0.703	63.93

#### 1.2 Standby Power

**Standard:** the standby power should be no more than 200mW at input 120Vac and remote dim off.

**Result:** Pass

Vin(Vac)	Fin(Hz)	Pstb (mW)
108	60	168.46
120	60	182.35
132	60	197.3

#### 1.3 PST and SVM

**Standard:** PST<1, SVM<1.6 @ 120Vac input & full load.

**Result:** Pass

PST	SVM
0.3	0.777

#### 1.4 Dimming Curve

**Standard:**

- the degree of dimming linearity should be as small as possible.
- C and W channel dimming curves should keep as consistent as possible; R, G and B channel dimming curves should keep as consistent as possible.

**Result:** Pass

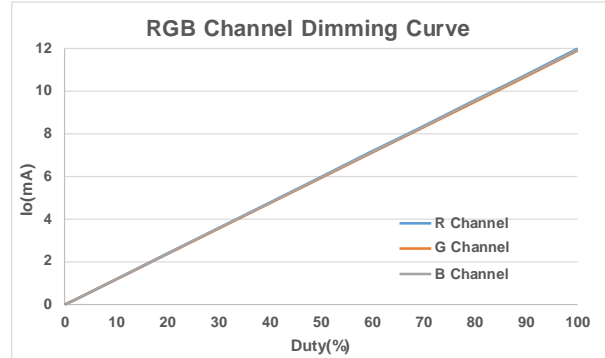
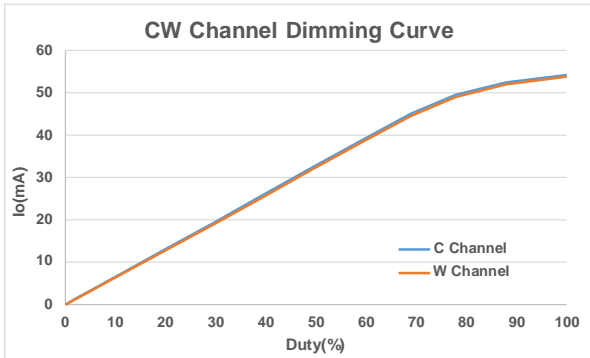

## 2. Dynamic characteristics

### 2.1 Power On

#### Standard:

1. the startup time should no more than 300ms;
2. the rising process of output current should be smooth with different duty under CW mode and RGB mode.

Result: Pass

#### Waveforms (CW Mode):

Test Condition: 120Vac/60Hz Input,  
Duty: (C: 100%, W: 0%)

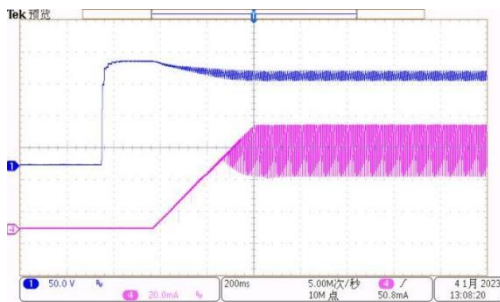

(CH1-Vbus, CH4-Io\_C)

Comments: Startup time = 218ms

Test Condition: 120Vac/60Hz Input,  
Duty: (C: 50%, W: 50%)

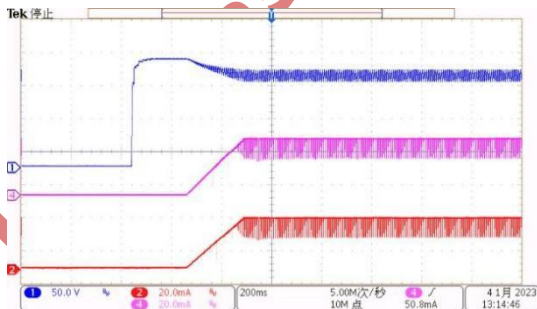

(CH1-Vbus, CH2-Io\_W, CH4-Io\_C)

Comments: CW Channel Start at the same time

Test Condition: 120Vac/60Hz Input,  
Duty: (C: 1%, W: 0%)

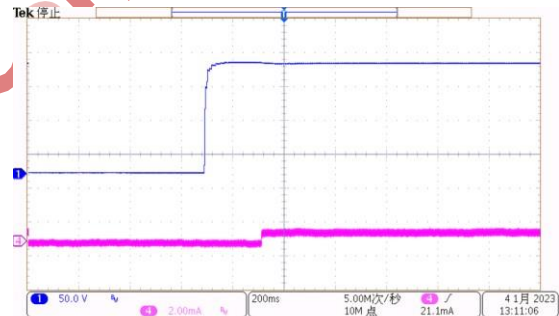

(CH1-Vbus, CH4-Io\_C)

Comments: Startup time = 218ms

Test Condition: 120Vac/60Hz Input,  
Duty: (C: 90%, W: 10%)

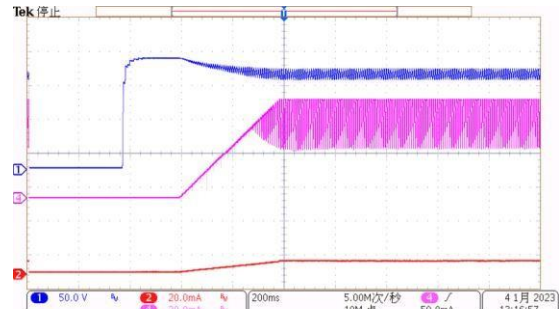

(CH1-Vbus, CH2-Io\_W, CH4-Io\_C)

Comments: CW Channel Start at the same time

**Note:** There exist some burrs in the current waveforms due to the changing duty cycle and the burrs do not affect the smoothness of the dimming process. Similar situations also appear in part of results below and no more detailed description.

Waveforms (RGB Mode):

Test Condition: 120Vac/60Hz Input,  
Duty: (R: 100%, G: 0%, B: 0%)

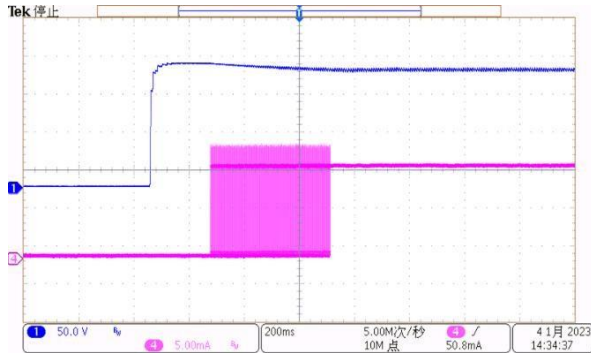

(CH1-Vbus, CH4-Io\_R)

Comments: Startup Time=218ms

Test Condition: 120Vac/60Hz Input,  
Duty: (R: 33%, G: 33%, B: 33%)

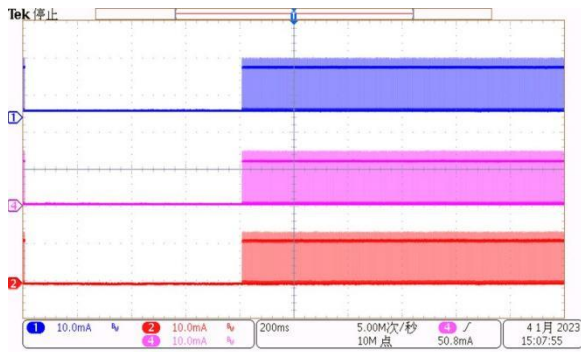

(CH1-Io\_B, CH2-Io\_G, CH4-Io\_R)

Comments: RGB Channel Start at the same time

Test Condition: 120Vac/60Hz Input,  
Duty: (R: 1%, G: 0%, B: 0%)

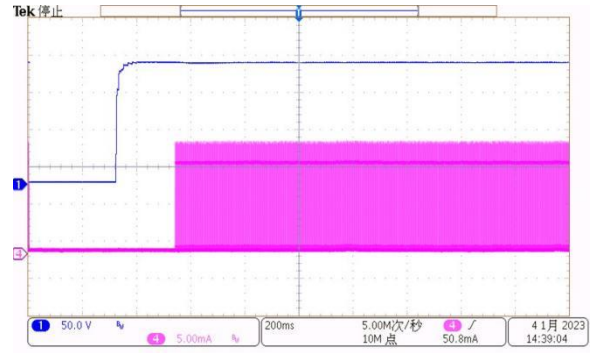

(CH1-Vbus, CH4-Io\_R)

Comments: Startup Time=218ms

Test Condition: 120Vac/60Hz Input,  
Duty: (R: 80%, G: 50%, B: 20%)

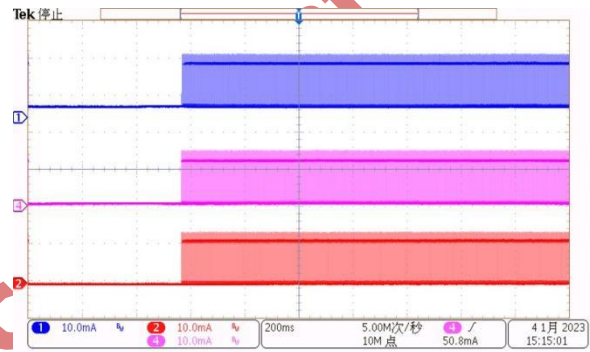

(CH1-Io\_B, CH2-Io\_G, CH4-Io\_R)

Comments: RGB Channel Start at the same time

2.2 Power Off

**Standard:** the falling process of output current should be smooth and have no noticeable upwarp with different duty under CW mode and RGB mode.

**Result:** Pass

Waveforms (CW Mode):

Test Condition: 120Vac/60Hz Input,  
Duty: (C: 100%, W: 0%)

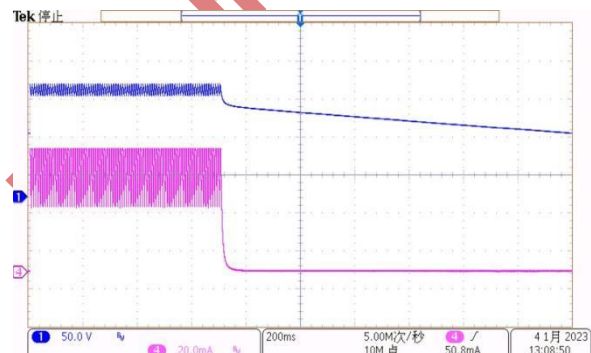

(CH1-Vbus, CH4-Io\_C)

Comments: Power Off OK

Test Condition: 120Vac/60Hz Input,  
Duty: (C: 1%, W: 0%)

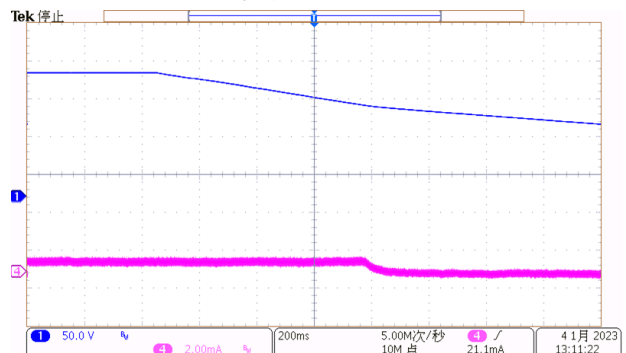

(CH1-Vbus, CH4-Io\_C)

Comments: Power Off OK

Test Condition: 120Vac/60Hz Input,  
Duty: (C: 50%, W: 50%)

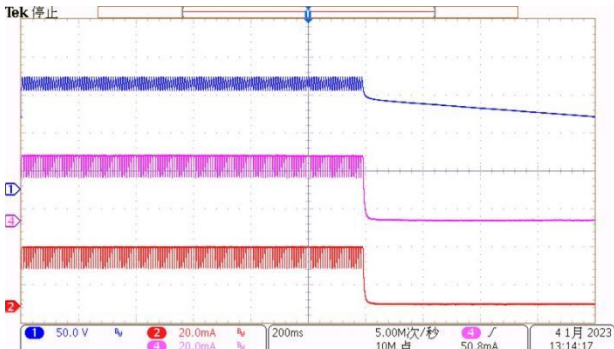

(CH1-Vbus, CH2-Io\_W, CH4-Io\_C)

Comments: CW Channel Stop at the same time

Test Condition: 120Vac/60Hz Input,  
Duty: (C: 90%, W: 10%)

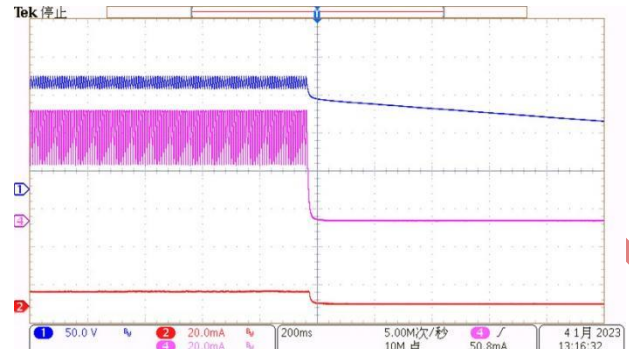

(CH1-Vbus, CH2-Io\_W, CH4-Io\_C)

Comments: CW Channel Stop at the same time

### Waveforms (RGB Mode):

Test Condition: 120Vac/60Hz Input,  
Duty: (R: 100%, G: 0%, B: 0%)

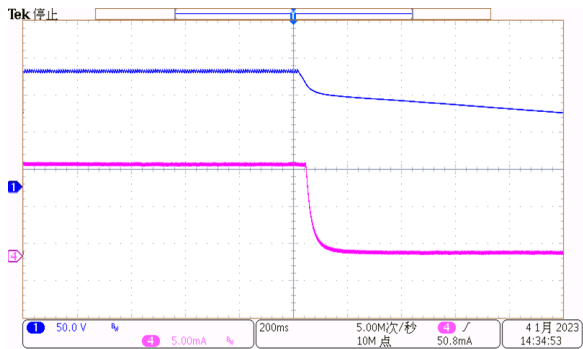

(CH1-Vbus, CH4-Io\_R)

Comments: Power Off OK

Test Condition: 120Vac/60Hz Input,  
Duty: (R: 1%, G: 0%, B: 0%)

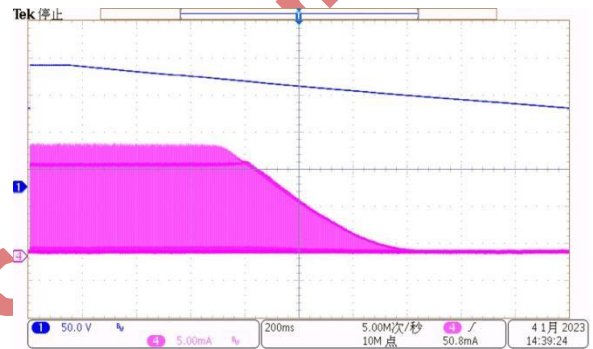

(CH1-Vbus, CH4-Io\_R)

Comments: Power Off OK

Test Condition: 120Vac/60Hz Input,  
Duty: (R: 33%, G: 33%, B: 33%)

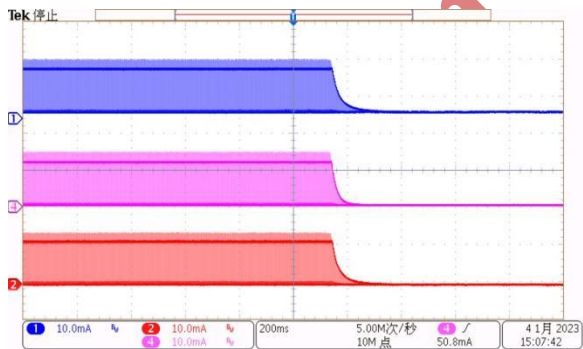

(CH1-Io\_B, CH2-Io\_G, CH4-Io\_R)

Comments: RGB Channel Stop at the same time

Test Condition: 120Vac/60Hz Input,  
Duty: (R: 80%, G: 50%, B: 20%)

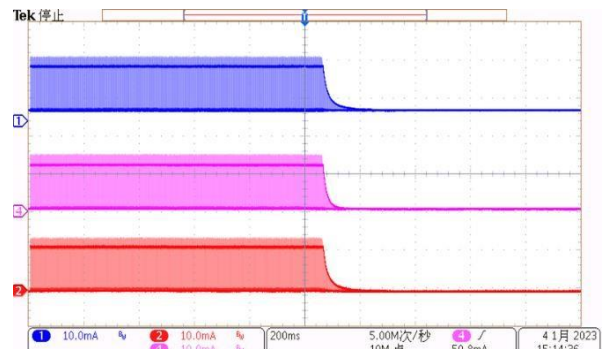

(CH1-Io\_B, CH2-Io\_G, CH4-Io\_R)

Comments: RGB Channel Stop at the same time

### 2.3 Dimming On

**Standard:** the rising process of output current should be smooth with different duty under CW mode and RGB mode.

**Result:** Pass



Waveforms (CW Mode):

Test Condition: 120Vac/60Hz Input,  
Duty: (C: 100%, W: 0%)

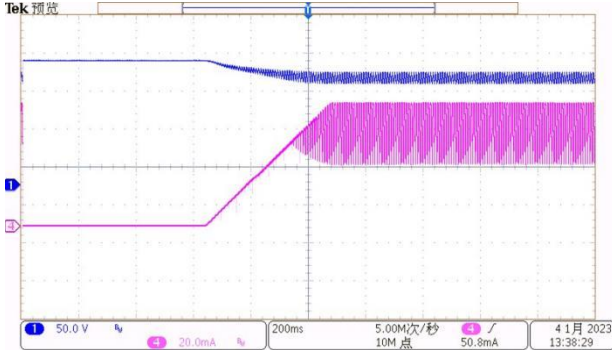

(CH1-Vbus, CH4-Io\_C)  
Comments: DIM ON OK

Test Condition: 120Vac/60Hz Input,  
Duty: (C: 1%, W: 0%)

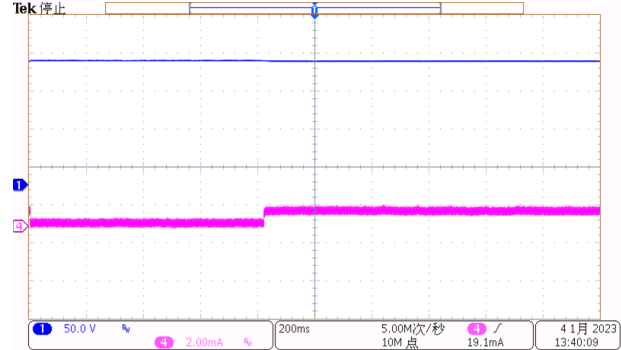

(CH1-Vbus, CH4-Io\_C)  
Comments: DIM ON OK

Test Condition: 120Vac/60Hz Input,  
Duty: (C: 50%, W: 50%)

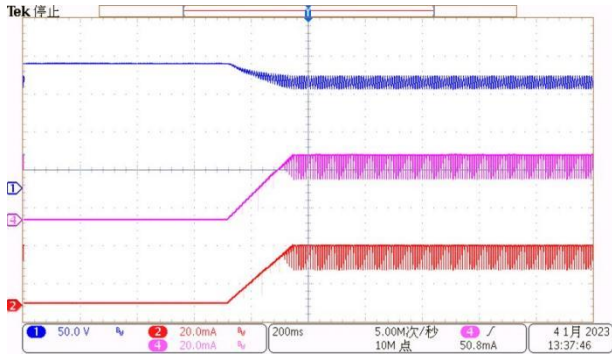

(CH1-Vbus, CH2-Io\_W, CH4-Io\_C)  
Comments: CW Channel DIM ON at the same time

Test Condition: 120Vac/60Hz Input,  
Duty: (C: 90%, W: 10%)

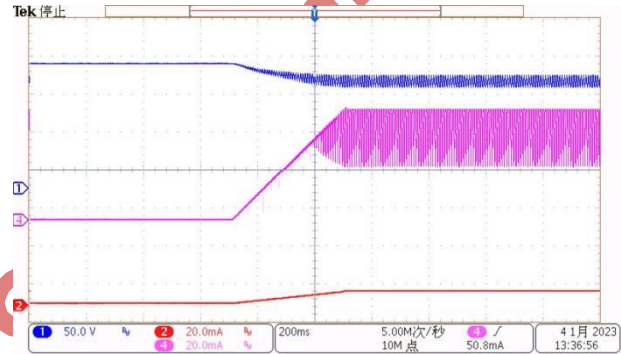

(CH1-Vbus, CH2-Io\_W, CH4-Io\_C)  
Comments: CW Channel DIM ON at the same time

Waveforms (RGB Mode):

Test Condition: 120Vac/60Hz Input,  
Duty: (R: 100%, G: 0%, B: 0%)

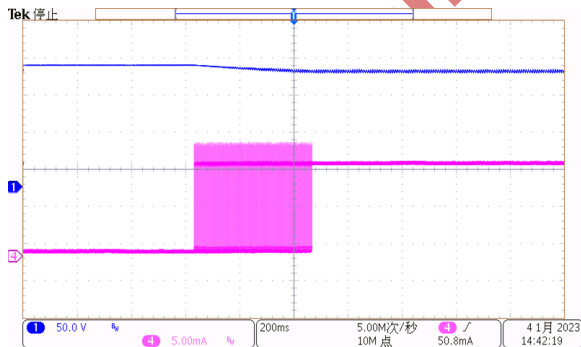

(CH1-Vbus, CH4-Io\_R)  
Comments: DIM ON OK

Test Condition: 120Vac/60Hz Input,  
Duty: (R: 1%, G: 0%, B: 0%)

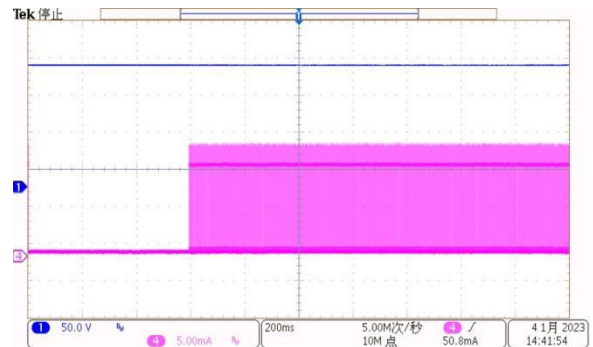

(CH1-Vbus, CH4-Io\_R)  
Comments: DIM ON OK

**Test Condition:** 120Vac/60Hz Input,  
Duty: (R: 33%, G: 33%, B: 33%)

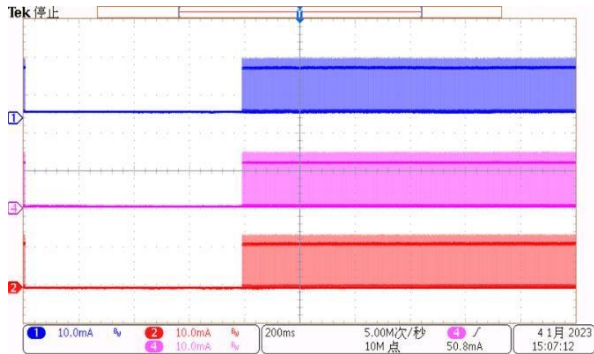

(CH1-Io\_B, CH2-Io\_G, CH4-Io\_R)

**Comments:** RGB Channel DIM ON at the same time

**Test Condition:** 120Vac/60Hz Input,  
Duty: (R: 80%, G: 50%, B: 20%)

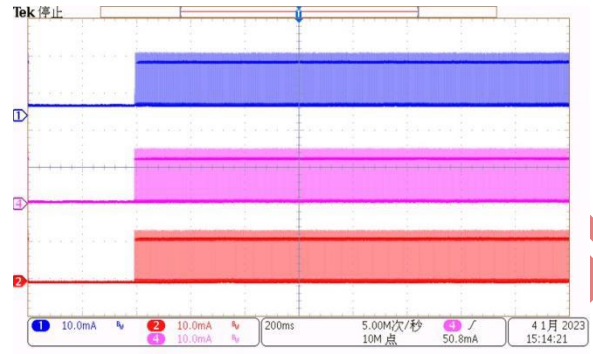

(CH1-Io\_B, CH2-Io\_G, CH4-Io\_R)

**Comments:** RGB Channel DIM ON at the same time

### 2.4 Dimming Off

**Standard:** the falling process of output current should be smooth with different duty under CW mode and RGB mode.

**Result:** Pass

#### Waveforms (CW Mode):

**Test Condition:** 120Vac/60Hz Input,  
Duty: (C: 100%, W: 0%)

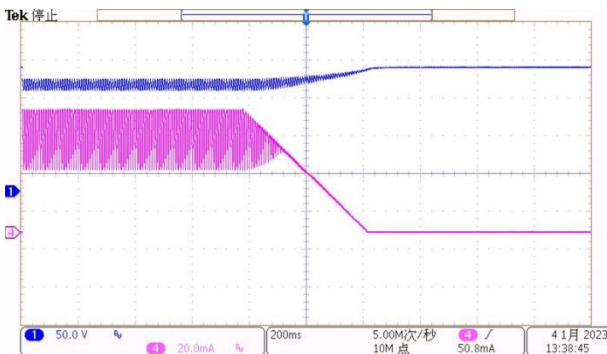

(CH1-Vbus, CH4-Io\_C)  
**Comments:** DIM OFF OK

**Test Condition:** 120Vac/60Hz Input,  
Duty: (C: 50%, W: 50%)

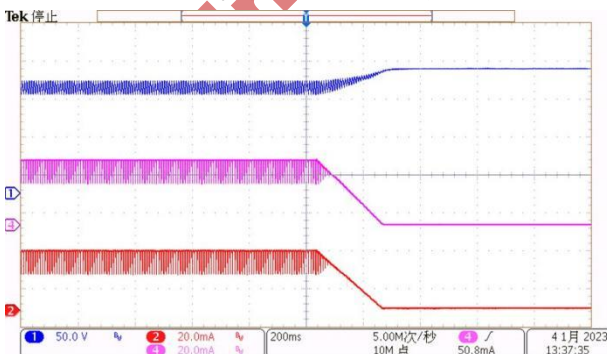

(CH1-Vbus, CH2-Io\_W, CH4-Io\_C)  
**Comments:** CW Channel DIM OFF at the same time

**Test Condition:** 120Vac/60Hz Input,  
Duty: (C: 1%, W: 0%)

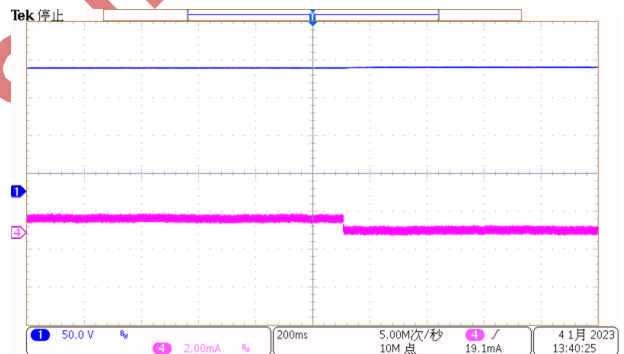

(CH1-Vbus, CH4-Io\_C)  
**Comments:** DIM OFF OK

**Test Condition:** 120Vac/60Hz Input,  
Duty: (C: 90%, W: 10%)

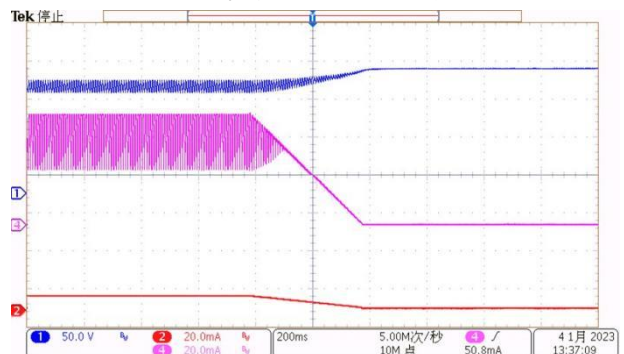

(CH1-Vbus, CH2-Io\_W, CH4-Io\_C)  
**Comments:** CW Channel DIM OFF at the same time

Waveforms (RGB Mode):

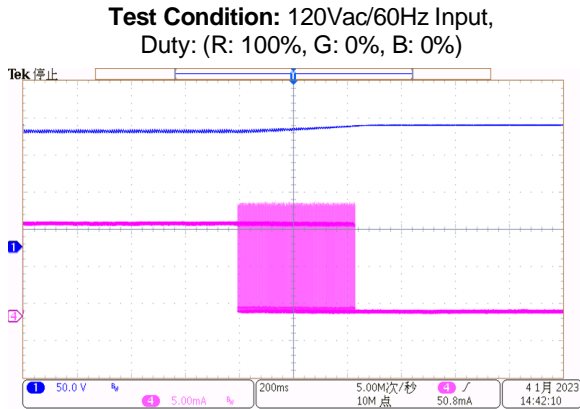

(CH1-Vbus, CH4-Io\_R)  
Comments: DIM OFF OK

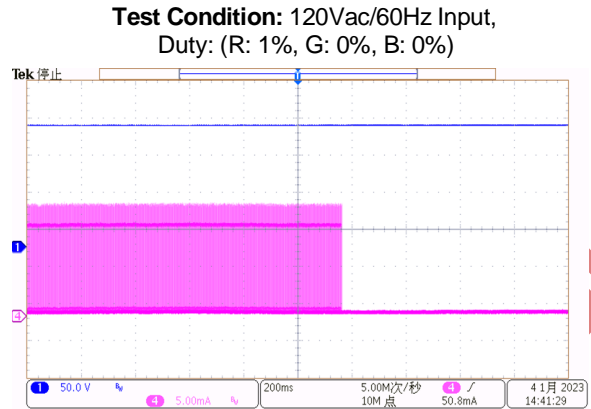

(CH1-Vbus, CH4-Io\_R)  
Comments: DIM OFF OK

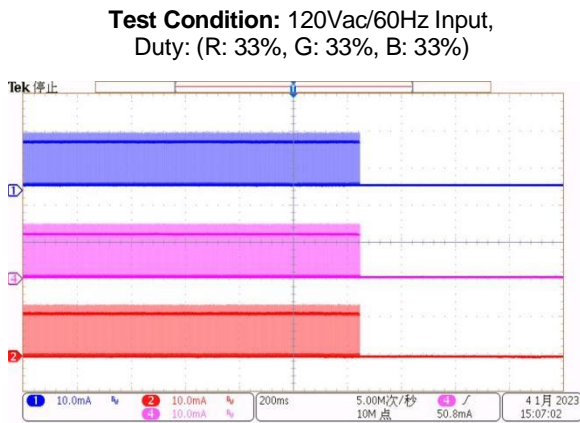

(CH1-Io\_B, CH2-Io\_G, CH4-Io\_R)  
Comments: RGB Channel DIM OFF at the same time

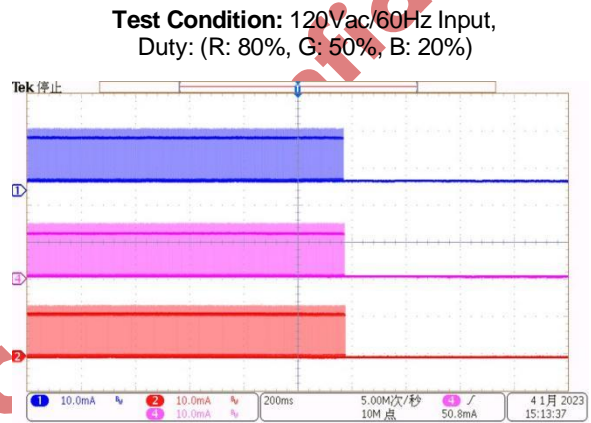

(CH1-Io\_B, CH2-Io\_G, CH4-Io\_R)  
Comments: RGB Channel DIM OFF at the same time

2.5 Dimming Dynamic

**Standard:** the color transitions of LEDs should be smooth, and the brightness of LEDs has no noticeable change when the duty changes.

**Result:** Pass

Waveforms (CW Mode):

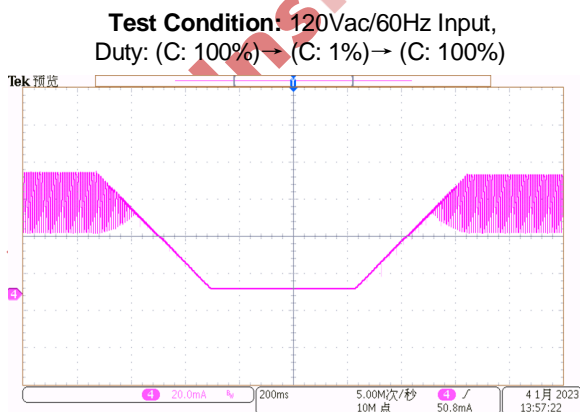

(CH4-Io\_C)  
Comments: Dimming OK

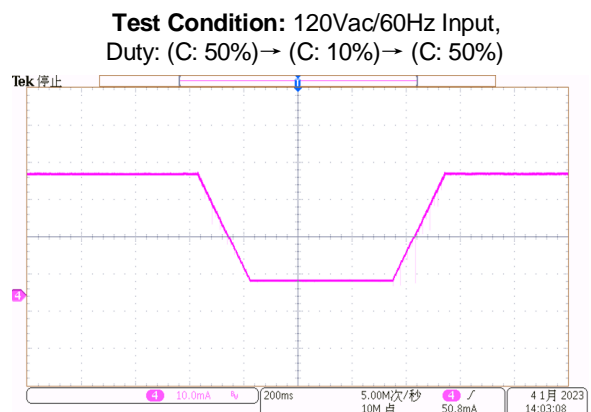

(CH4-Io\_C)  
Comments: Dimming OK

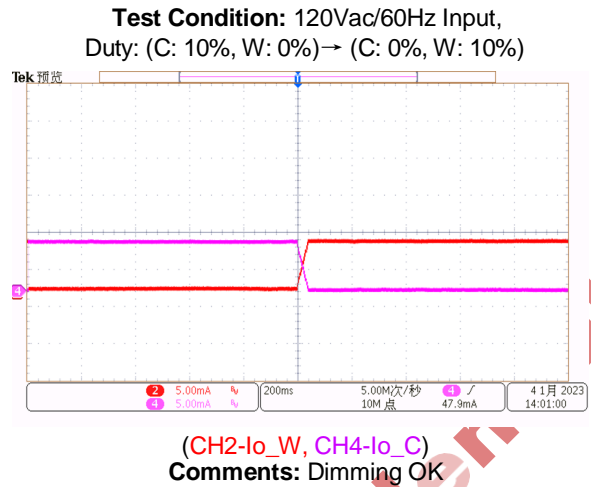
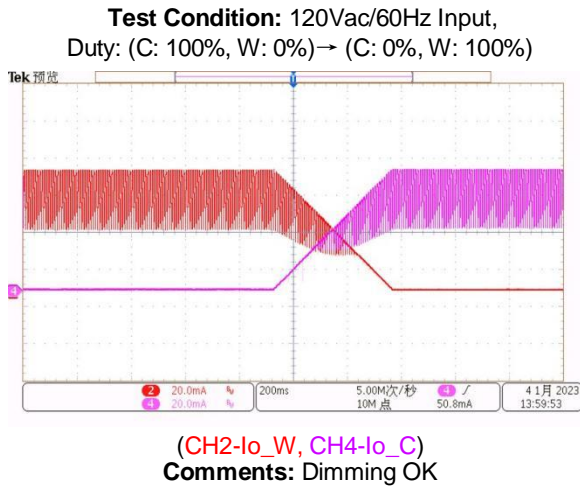

### 3. Thermal Test

**Standard:** CW mode:  $\Delta T < 90^{\circ}\text{C}$  (Limited  $115^{\circ}\text{C}$ ); RGB mode:  $\Delta T < 70^{\circ}\text{C}$

**Result:** Pass

**Test Condition:** Burn in for 1 hour in the A60 lamp cavity @ confined container (30cm\*30cm\*30cm plastic box) and steady environment with no airflow,  $T_a$  is the temperature inside the plastic box.

Component	Test Condition: CW Mode, Full Load		Test Condition: RGB Mode, Full Load	
	120Vac/60Hz		120Vac/60Hz	
	$T_a = 22^{\circ}\text{C}$		$T_a = 22.8^{\circ}\text{C}$	
	$T_c(^{\circ}\text{C})$	$T_{rise}(^{\circ}\text{C})$	$T_c(^{\circ}\text{C})$	$T_{rise}(^{\circ}\text{C})$
KP18058ESPA	94.6	72.6	85.8	63
KP35026VGA	76.2	54.2	66.9	44.1
Light Board	96.5	74.5	84.1	61.3

### 4. EMC/EMS Test

**Standard:**

Standard	EN55015
Content	CE/RE
Requirement	6 dB Margin

#### 4.1 Conducted Emissions

**Result:** Pass



**108~150VAC/60HZ, PF>0.7, CW 140V/55mA and RGB 140V/12mA  
Five-Channel Linear Solution for Smart LED with KP18058**

**Test Condition:** Vin=120VAC/60Hz, CW Mode, Full Load

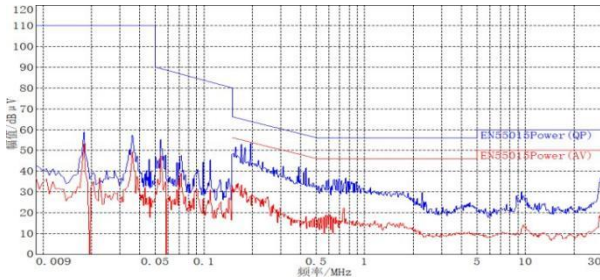

Conduction EMI---LINE

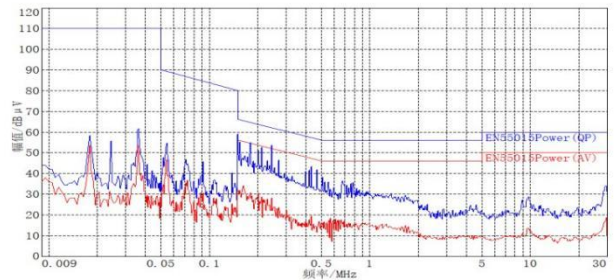

Conduction EMI---NEUTRAL

**Test Condition:** Vin=120VAC/60Hz, RGB Mode, Full Load

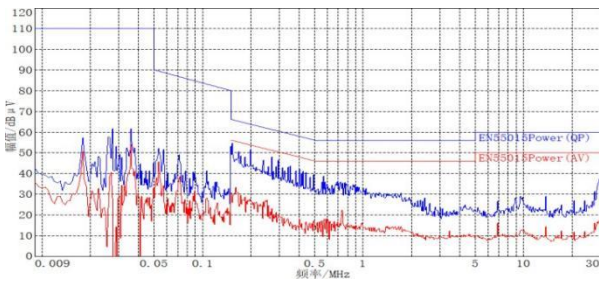

Conduction EMI---LINE

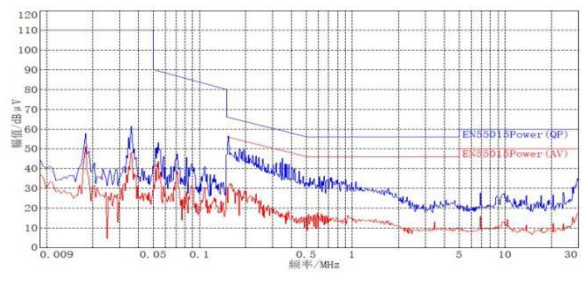

Conduction EMI---NEUTRAL

**4.2 Radiated Emissions**

**Result:** Pass

**Test Condition:** Vin=120VAC/60Hz, CW Mode, Full Load

**Test Condition:** Vin=120VAC/60Hz, RGB Mode, Full Load

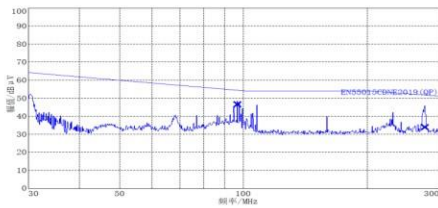

(QP)	Freq(MHz)	Lev(dB μV)	Lim(dB μV)	Δ(Lev-Lim)	---final test
	96.800	46.500	54.270	-7.770	
	276.000	33.900	51.617	-17.717	

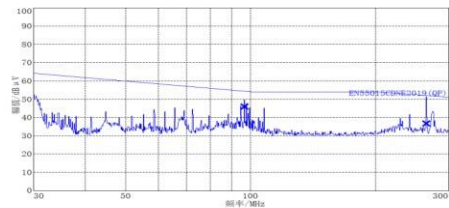

(QP)	Freq(MHz)	Lev(dB μV)	Lim(dB μV)	Δ(Lev-Lim)	---final test
	96.800	45.800	54.270	-8.470	
	265.600	36.524	51.901	-15.377	

**5. Surge Test**

Input voltage was set at 120VAC/60Hz. Output was loaded at full load and operation was verified following each surge event. Each injection phase below is tested with 5 times and hold for 30 seconds before next one.

**Result:** Pass



**108~150VAC/60HZ, PF>0.7, CW 140V/55mA and RGB 140V/12mA  
Five-Channel Linear Solution for Smart LED with KP18058**

Input Voltage (VAC)	Surge Level (V)	Injection Location	Injection Phase (°)	Test Result (Pass/Fail)
120Vac/60Hz	+1000	L to N	0	Pass
	+1000	L to N	90	Pass
	+1000	L to N	180	Pass
	+1000	L to N	270	Pass
	-1000	L to N	0	Pass
	-1000	L to N	90	Pass
	-1000	L to N	180	Pass
	-1000	L to N	270	Pass

### Test Setup Guide

1. Set the AC Power Source between 108VAC and 150VAC.
2. Connect the AC Power Source terminal to the “L” and “N” terminals on the Demo Board
3. Turn on the AC Power Source to make system startup; and Turn off the AC Power Source to make system shutdown.



**108~150VAC/60HZ, PF>0.7, CW 140V/55mA and RGB 140V/12mA  
Five-Channel Linear Solution for Smart LED with KP18058**

**Revision History**

DATE	REV	DESCRIPTION
2023/01/09	1.0	First Release

**Kiwi Instruments Corp. Confidential**

**Disclaimer**

Kiwi reserves the right to make any change to its product, datasheet or specification without any notice. Users shall obtain the latest information before placing an order. Kiwi herein makes no guarantee or warranty, expressed or implied, including without limitation the warranties of merchantability, fitness for any purpose or non-infringement of third party rights, nor does Kiwi convey any license or permission including without limitation the intellectual property rights of Kiwi or any third party. Users should warrant that third party intellectual property right or other right is not infringed when integrating Kiwi products into any application or in use. Kiwi will not assume any liability arising from any said application or use, and especially disclaim any liability including without limitation any consequential or incidental damage. Without written declaration, Kiwi products are not designed for use in surgical device implant into the body or other life sustain systems. This disclaimer supersedes the disclaimers in previous versions.